

- 3. Reference designators with an A prefix are part of the chassis sub-assembly.
 - 2. All TL072s have +15 Volts to pin 6, and -15 Volts to pin 4.
 - 1. All resistors are Ohms, 1/4 Watt
- NOTES (Unless otherwise indicated):

SMR SOUND CORPORATION	
Title WORKINGMAN'S 12 PREAMP & AURAL ENHANCER	
Size Document Number	REV
8	700032-2
Date	April 8, 1978 Sheet 2 of 3

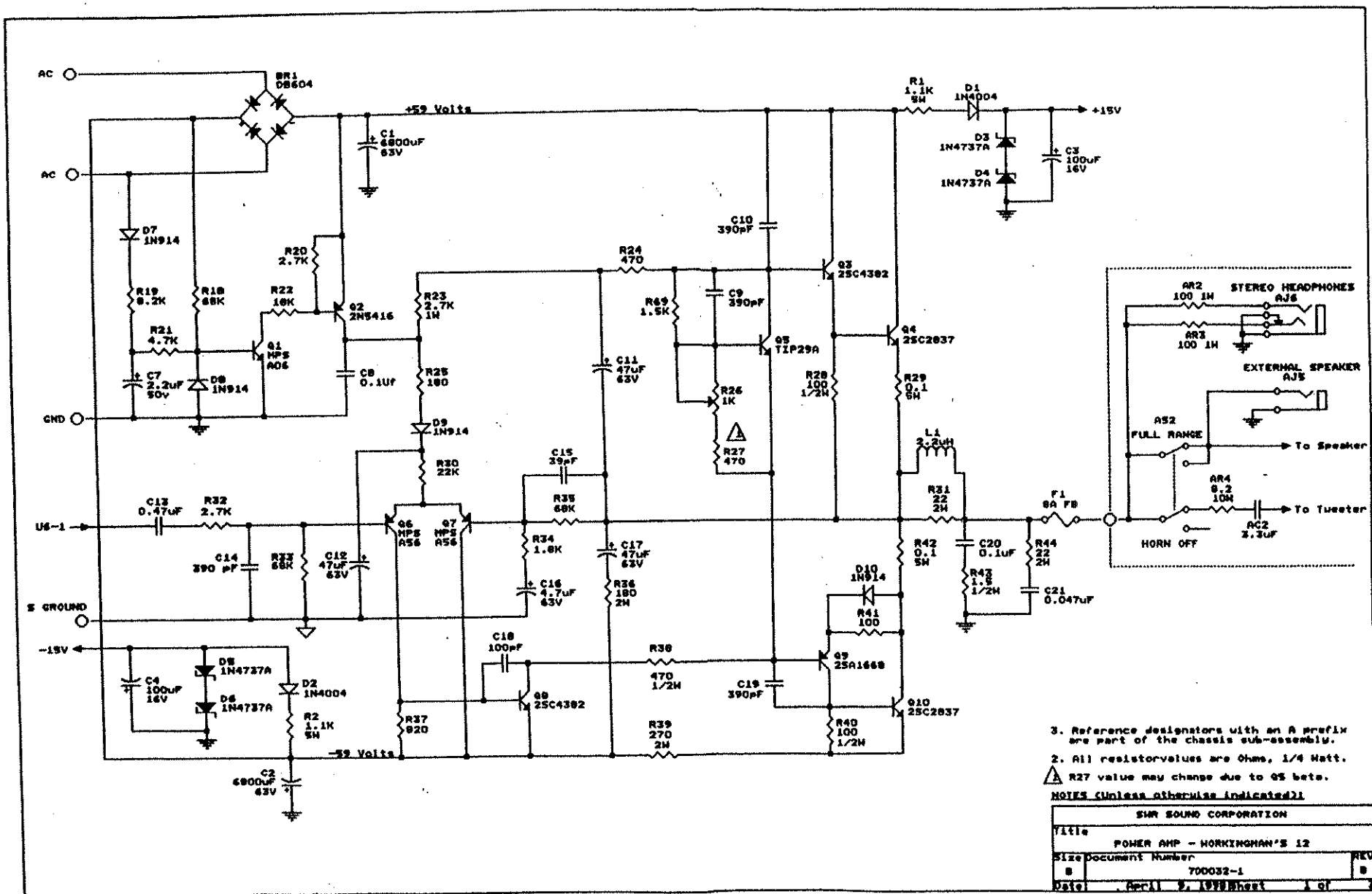

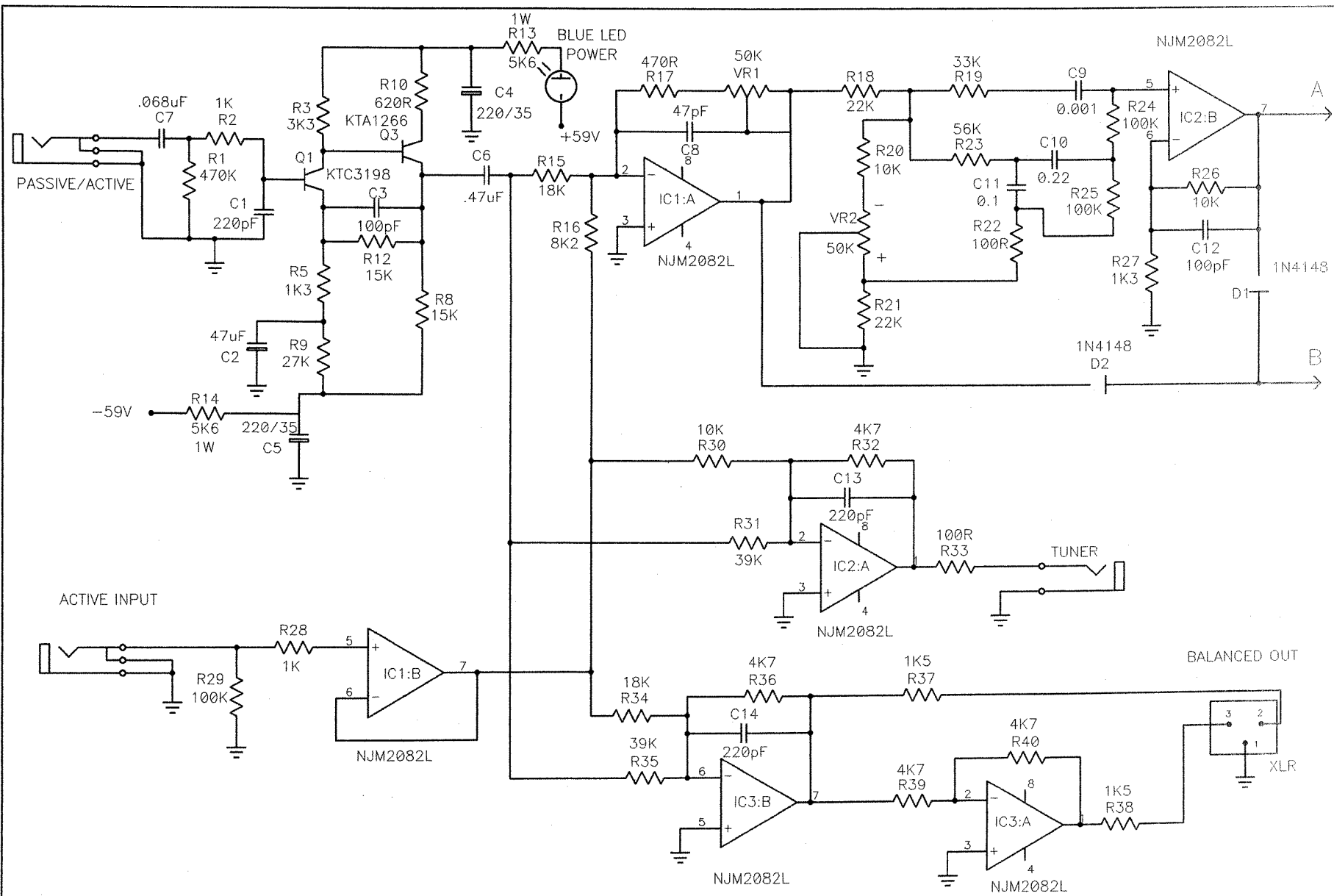

TITLE WORKINGMAN'S 12 EQ	FILENAME WKG12.S05
DRAWN BY M.NICHOLLS	DATE 1/3/99
	REV B

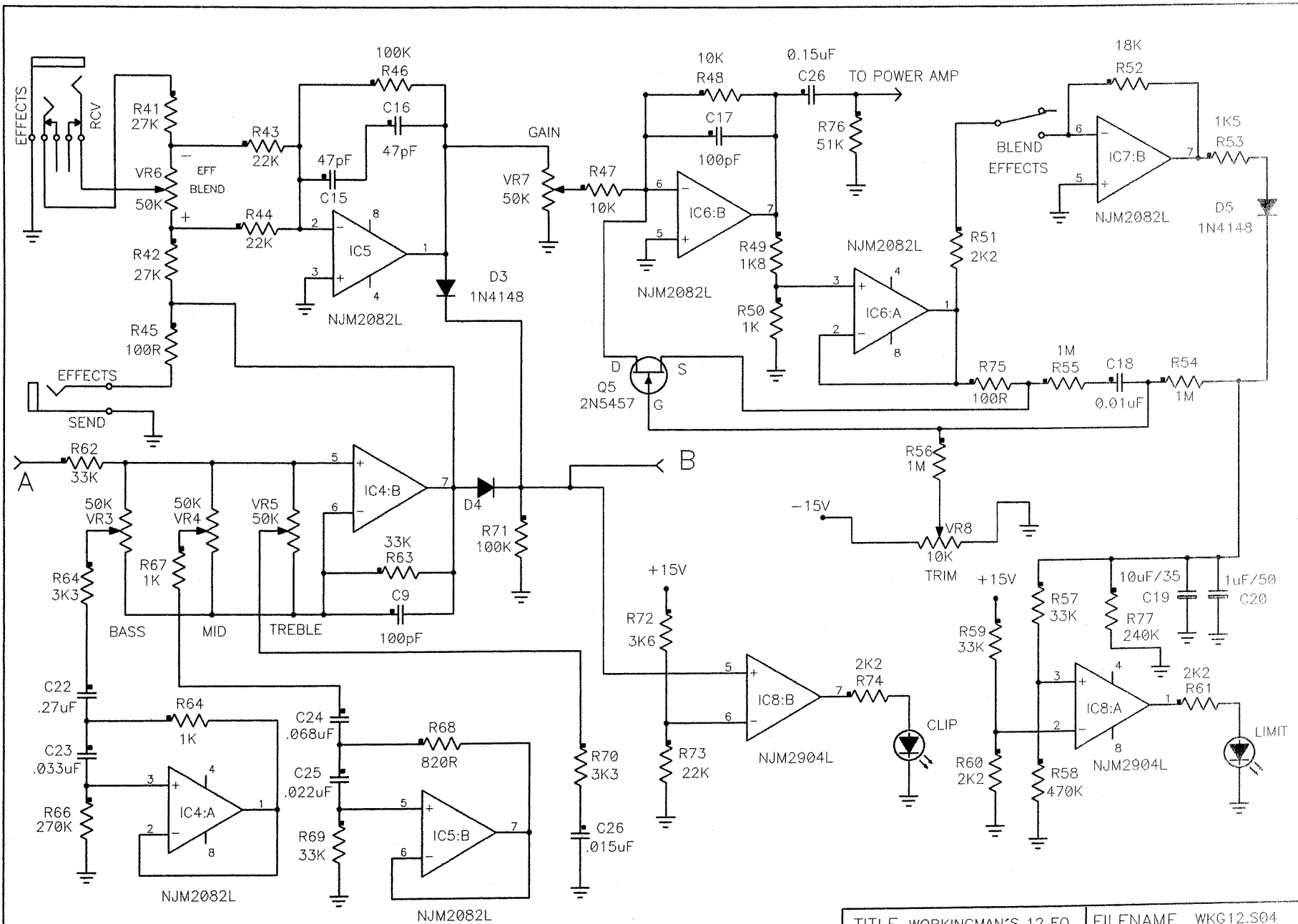

TITLE WORKINGMAN'S 12 EQ	FILENAME WKG12.S04
DRAWN BY M.NICHOLLS	DATE 1/3/99 REV B

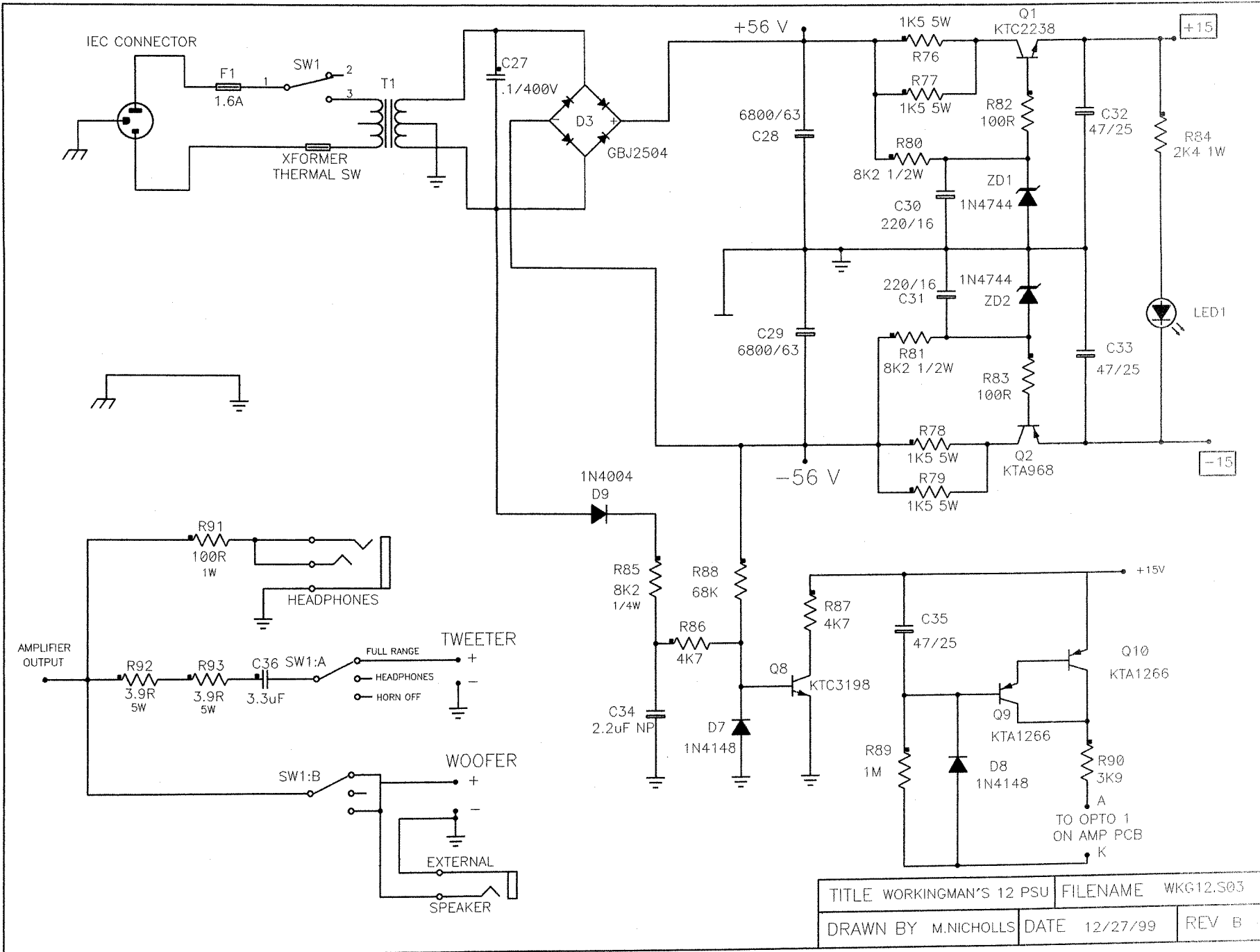

TITLE WORKINGMAN'S 12 PSU	FILENAME WKG12.S03
DRAWN BY M.NICHOLLS	DATE 12/27/99
	REV B

6

5

4

3

2

1

REVISION RECORD			
LTR	ECO NO:	APPROVED:	DATE:

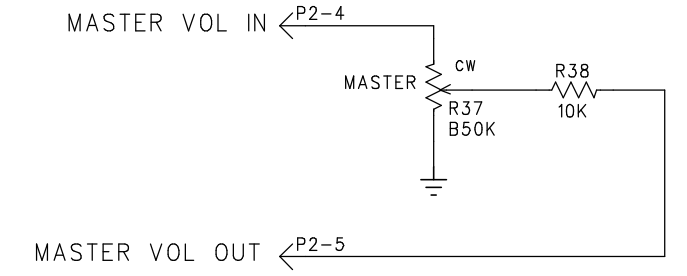
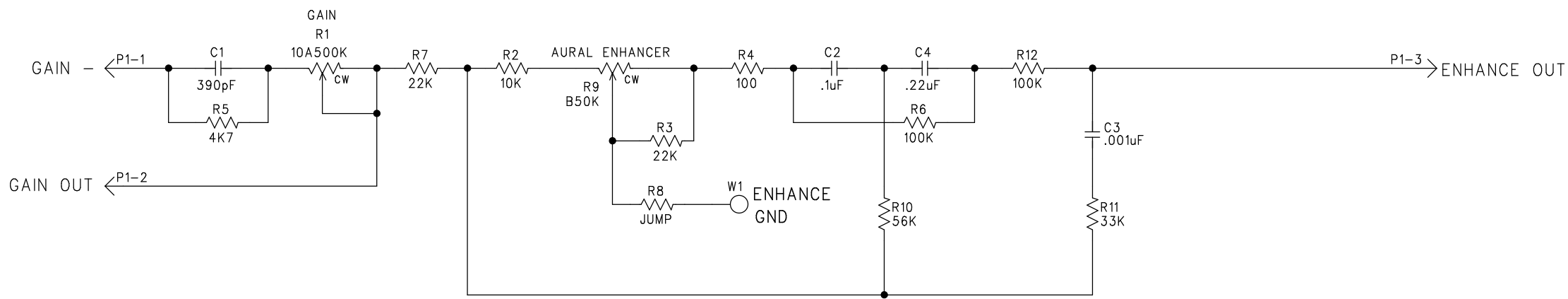

*This resistor tacked on pcb in previous design.

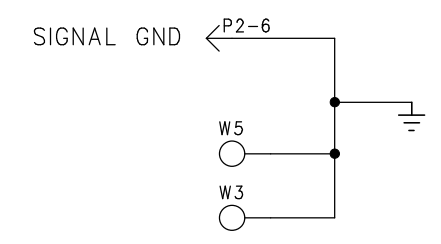
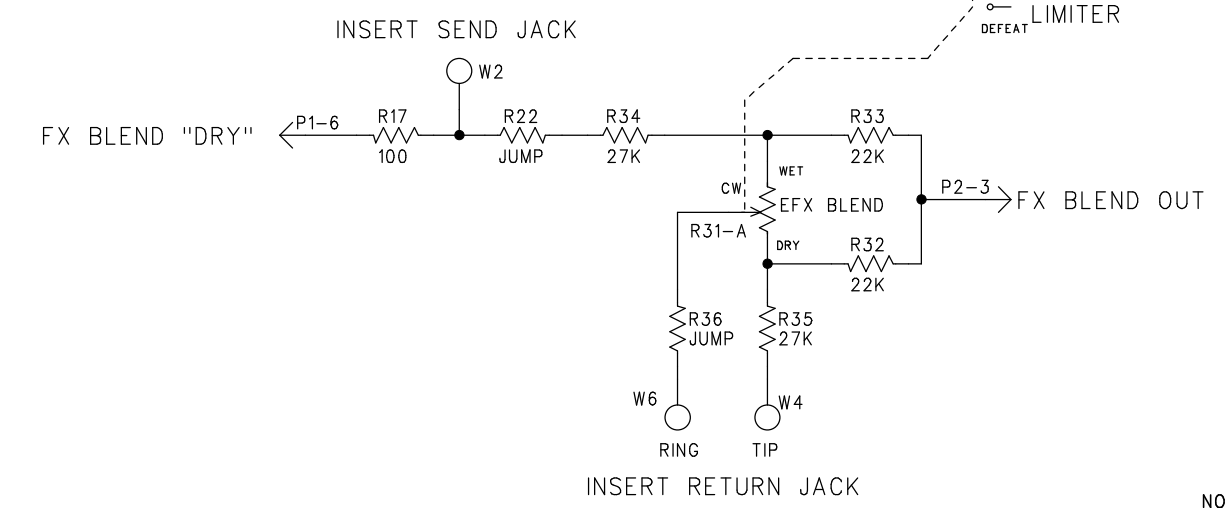
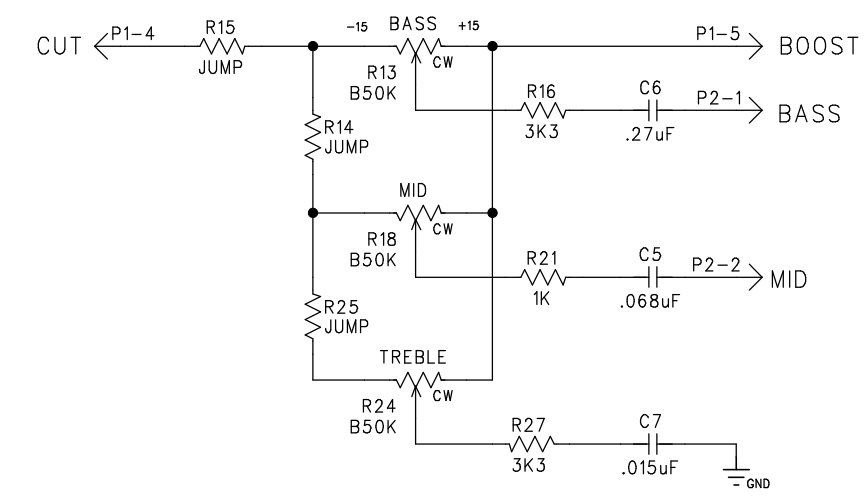
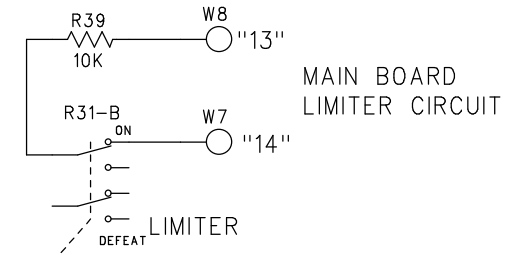

NOTES:
 UNLESS OTHERWISE NOTED:
 1. ALL RESISTORS ARE 5% 1/4W
 2. REFERENCE DESIGNATORS STARTING WITH "W" INDICATE PADS FOR WIRES THAT ARE SOLDERED TO THE PCB.
 3. ALL RESISTOR VALUES IN OHMS

COMPANY: SWR Sound Corporation 9130 Glenoaks Blvd., Sun Valley, CA 91352	
TITLE: Workingman's 12 Control/ EQ PCB	
SIZE: Part #170020	REV: B
C Assy #700033	
Date: 08MAY03	Engineer: Drawn by: JY
Filename:	SHEET: 1 OF 1

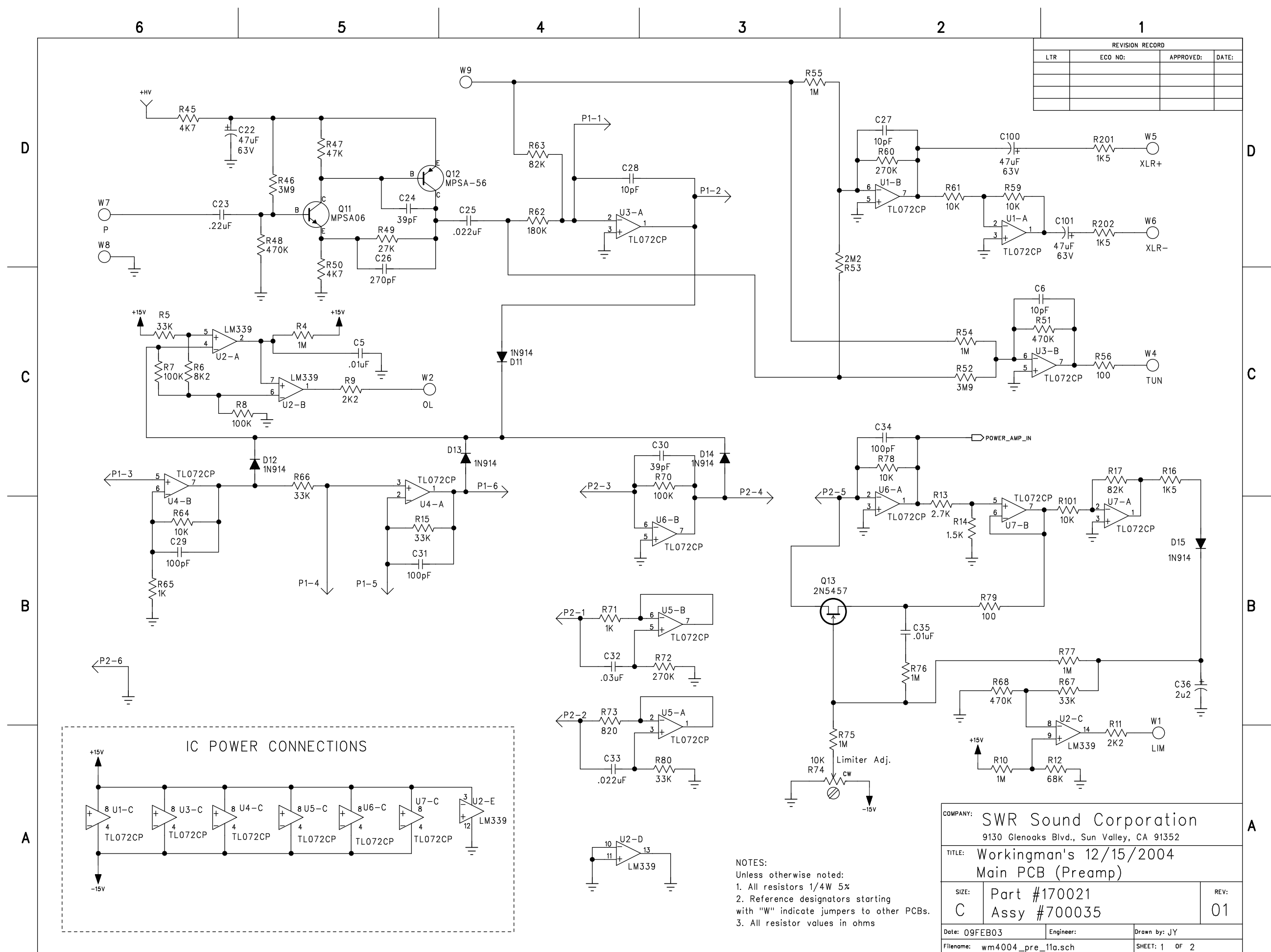

REVISION RECORD			
LTR	ECO NO.	APPROVED:	DATE:

- NOTES:
 Unless otherwise noted:
 1. All resistors 1/4W 5%
 2. Reference designators starting with "W" indicate jumpers to other PCBs.
 3. All resistor values in ohms

COMPANY: SWR Sound Corporation		
9130 Glenoaks Blvd., Sun Valley, CA 91352		
TITLE: Workingman's 12/15/2004 Main PCB (Preamp)		
SIZE: C	Part #170021 Assy #700035	REV: 01
Date: 09FEB03	Engineer:	Drawn by: JY
Filename: wm4004_pre_11a.sch	SHEET: 1 OF 2	

PRELIMINARY

6 5 4 3 2 1

REVISION RECORD			
LTR	ECO NO:	APPROVED:	DATE:

D
C
B
A

D
C
B
A

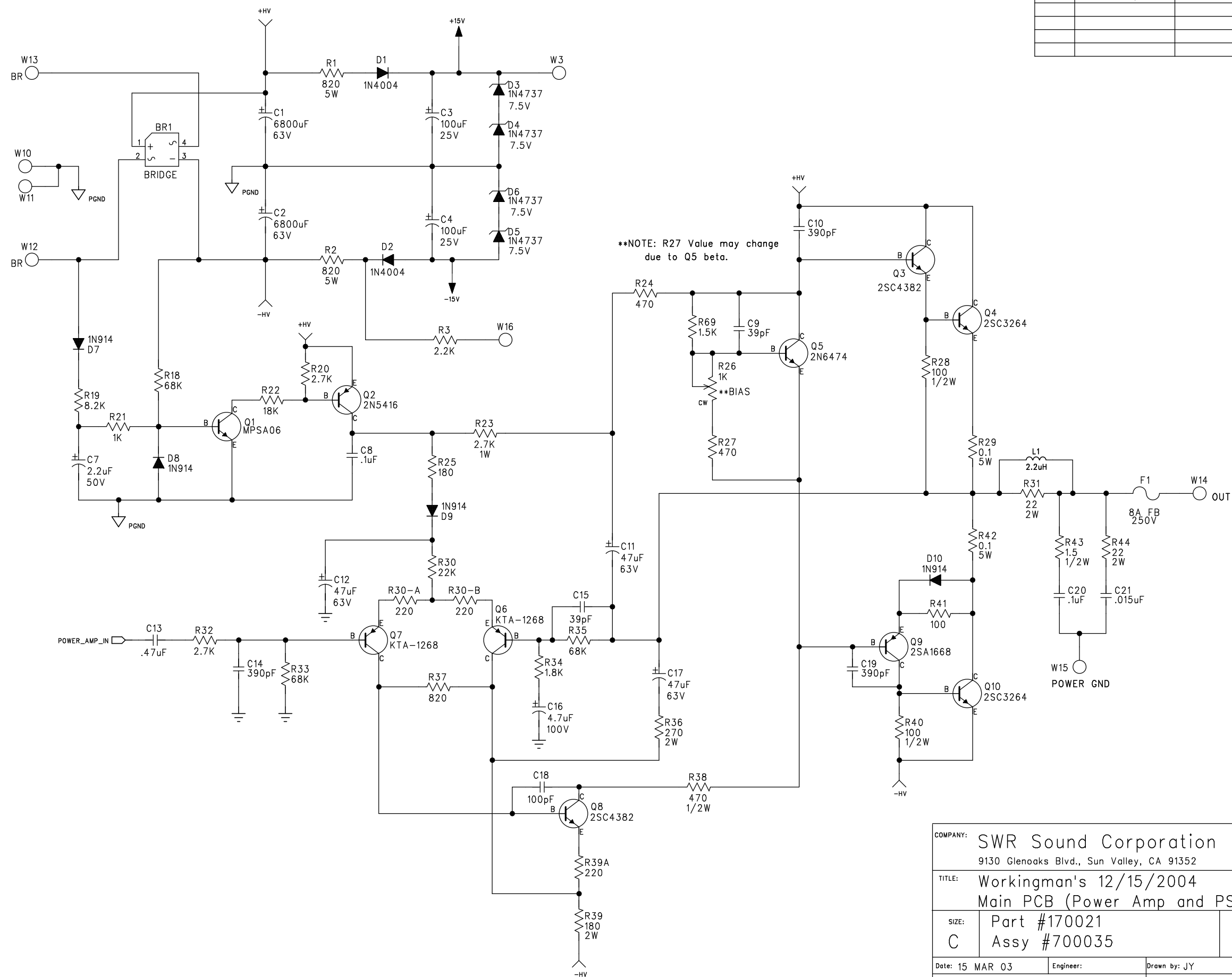

COMPANY: SWR Sound Corporation		A
9130 Glenoaks Blvd., Sun Valley, CA 91352		
TITLE: Workingman's 12/15/2004 Main PCB (Power Amp and PSU)		
SIZE: Part #170021	REV: 01	
C	Assy #700035	
Date: 15 MAR 03	Engineer:	Drawn by: JY
Filename:		SHEET: 2 OF 2

TEST PROCEDURE, WORKINGMAN'S 12/15

1. Visually check unit for:
 - A. Correct polarity position of all electrolytic capacitors.
 - B. All I.C.'s are firmly in their sockets.
 - C. All wires are soldered to their respective locations.
 - D. Correct lead dress of ground wires.
 - E. Any cut leads, wires fragments or other foreign objects that should not be in unit (shake out before testing).
 - F. Speaker hot leads are taped to prevent shorting.
 - G. Speaker leads are wired correctly.
 - H. Headphone jack is wired correctly.
- * Check for loose connections during all phases of testing.
2. Set output of generator for 120 millivolts at 1KHz.
- ③ Set bias of power amplifier at 2 ohms. Run input signal through the effects return jack thereby checking effects blend. There should be no signal with effects blend in the dry position.
4. Change generator to 100Hz. Change load to 8 ohms. Maintain 120 millivolt level. Plug input into Passive input jack. Check gain of unit with enhancer off, tone controls set flat, gain and master volume full. Output power should be 100 watts RMS (28V RMS + or - 1dB). Check for operation of green limiter LED (should be lit).
5. Lower master volume to mid position. Raise bass control until preamp clips. Check preamp clip red LED for proper operation.
6. Reduce generator output by -20dB. Reduce gain control for total output of 1V RMS (use 10V scale on output meter).
 - A. check enhancer circuit at 40Hz and 180 Hz.
 - B. check bass control for cut and boost of 15dB @ 100Hz.
 - C. check mid range control for 20dB cut and boost @ 800Hz.
 - D. check treble control for 15dB cut and boost at 4KHz.
7. Check effects loop using patch cord and blend control.
8. Check tuner send and XLR out.
9. Remove input signal and check noise readings across speaker jack with tone controls flat, enhancer off.
 - A. Gain and master volume full: less than 15 millivolts (12 millivolts typical).
 - B. Gain and master volume off (full counter-clockwise): less than 1 millivolt (0.6 millivolts typical).

③ . Effects blend to wet position.
 . Raise Master volume level so that 2 volts RMS appears at the speaker output.

- . Monitor signal on scope with the following settings:
- Load 2 ohms
 - Scope: Sweep Time: 50 μ s Volts/Div: 0.2v.
 - Signal Generator: Freq. 1KHz

. The signal should have a prominent crossover notch at about
 . Adjust bias trimpot of Amp, just past the point the crossover notch disappears. ^{Or:}

BIAS PROCEDURE SM-400/SM-900/ST-800

Equipment required:

**Sinewave generator
2 ohm, 250 watt load
AC millivolt meter
Oscilloscope**

- 1. Lower signal generator output to minimum, set frequency to 1KHz and insert into "mono" effects return jack (unbalanced line in for Stereo 800).**
- 2. Set Power Amp Assign Switch on back panel to "Stereo" position (up). Plug 2 ohm dummy load in channel to be tested.**
- 3. Raise Master Volumes on SM-900 and ST-800 to full clockwise. Set Effects Blend control on SM-900 to "wet" (full clockwise). Set Balance control on SM-400 to mid-position.**
- 4. Adjust bias trim pots to full counter-clockwise position.**
- 5. Turn on/off switch to "on" position. Connect unit to autotransformer (variac) and raise AC line level to 115 volts.**
- 6. Position ground reference on oscilloscope just above center line of screen.**
- 7. Raise signal generator level so that 2 volts RMS appears at the speaker output.**
- 8. Monitor signal on scope with the following settings:
Load: 2 ohms
Scope: Sweep Time: 50us Volts/Div: 0.2V
Signal Generator: Freq. 1KHz**

9. The signal should have a prominent crossover notch at about zero crossing. Refer to diagram below.

Figure 1.

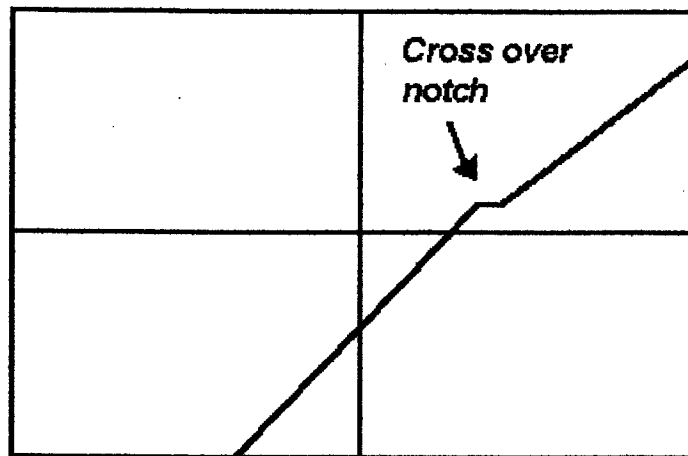

10. Adjust bias trimpot of amp being tested just past the point the crossover notch disappears. DO NOT OVER ADJUST as this will set the idle current too high and the power amp will overheat

11. Repeat procedure for other side.