

Stinger 20 and Stinger 60 OPERATOR'S MANUAL

1. INTRODUCTION.

The STINGER 20 and STINGER 60 are compact guitar amplifiers with features and performance designed to satisfy the most demanding musician. Combining **sunn's** proven CMOS overdrive circuitry with a medium power amplifier and a specially designed loudspeaker in an infinite baffle enclosure, the STINGER is capable of far more performance than its small size would imply.

Separate preamp GAIN and MASTER level controls allow the musician to play clean or dirty at whatever volume he chooses. When overdriven (by advancing the GAIN control), the STINGER distorts smoothly, controllably and musically, harmonically enriching the guitar's signal and increasing its sustain.

A headphones output jack permits the STINGER to be used privately as a practice amp and also doubles as a line level output jack, allowing the amp to be patched into the mixer of a PA system or to an additional power amplifier and speaker when greater volume is required. Also featured is a reverb system and reverb level control for added depth (STINGER 60 only).

The heavy-duty vinyl-covered cabinet and all-steel chassis construction insure rugged portability and long life.

Although very small and lightweight, **sunn's** STINGER 20 and STINGER 60 are extremely capable amplifiers, sure to give any guitarist many hours of playing enjoyment.

2. FEATURES

- FET input circuitry for high input impedance and good overload characteristics
- Separate preamp GAIN and MASTER level controls, allowing sustain and volume to be varied independently
- 3-band passive EQ
- Proven Cascaded CMOS Overdrive circuitry
- 20 watt RMS power amp on STINGER 20, 60 watts on STINGER 60
- Custom-designed loudspeaker (8" on STINGER 20, 12" on STINGER 60)
- Infinite baffle speaker enclosure for improved bass and midrange response
- Equalized HEADPHONES/LINE OUT jack
- Speaker mute switch
- Reverb and reverb level control (STINGER 60 only)
- AC powered
- Lighted power switch
- Rugged all-steel chassis construction
- Metal protective speaker grill
- Carrying handle

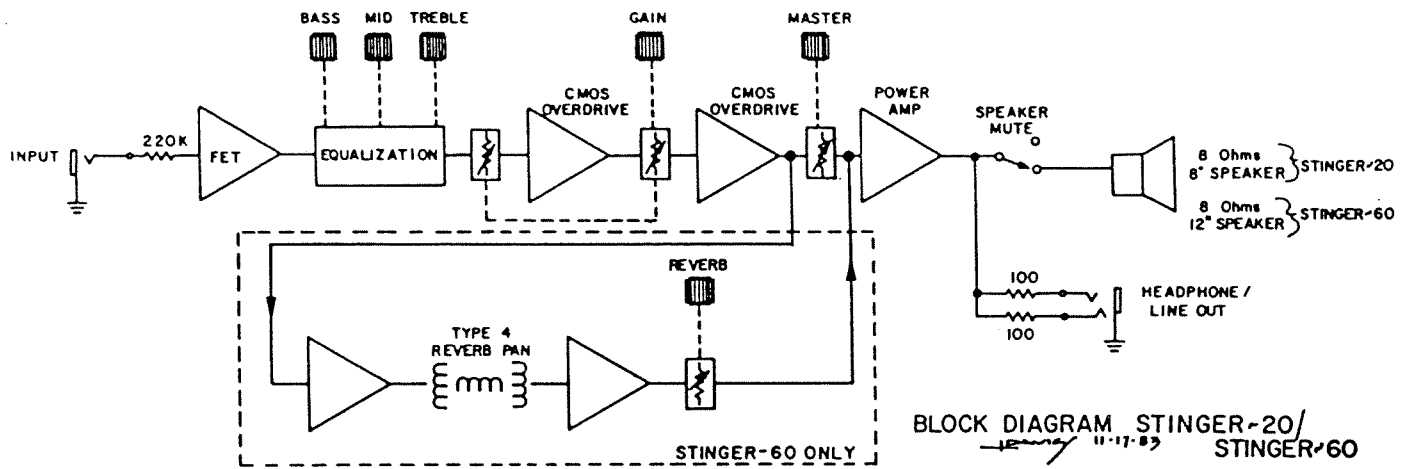

CIRCUIT DESCRIPTION. Signals entering the STINGER go first to FET (Field Effect Transistor) preamp stage. This stage prevents harsh-sounding hard clipping from occurring in later stages in the amp, and it buffers the signal prior to sending it on to the passive tone controls. From the tone controls, the signal passes through the first of two "ganged" preamp level controls, or GAIN controls (controls which share a common shaft and are rotated by the same knob), which determines how much signal will be sent on to the first of two CMOS overdrive circuits. From the first overdrive stage the signal passes through the second gang of the GAIN control and the second CMOS overdrive circuit. Low level signals pass through the overdrive circuits unchanged, producing a sound that is so clean and undistorted, and higher level signals cause the overdrive circuits to go into saturation, adding a pleasing, harmonically rich distortion and sustain to the signal.

After the signal leaves the CMOS overdrive, it passes through the MASTER level control which determines how much power is delivered to the speaker and to the HEADPHONE/LINE OUT jack. On the STINGER 60, part of the signal from the last CMOS overdrive stage goes to the reverb system and the delayed signal passes through the REVERB LEVEL control before recombining with the original, "dry" signal in the power amplifier. The SPEAKER MUTE switch allows the loudspeaker to be turned off when the STINGER 20 is used as a practice amp, insuring domestic tranquility.

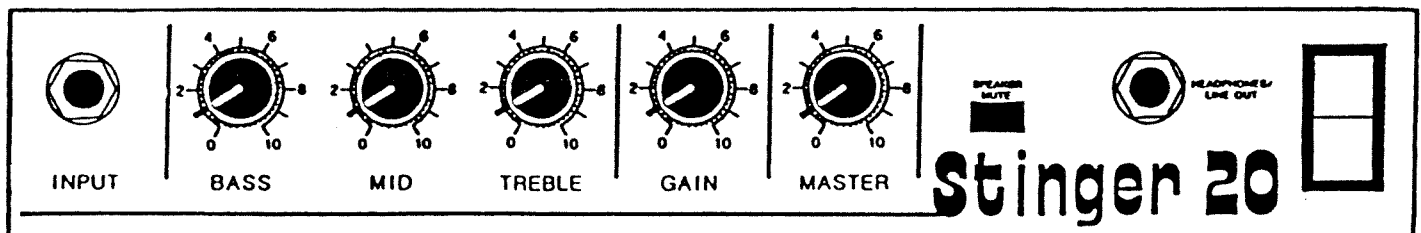

3. CONTROLS

INPUT. Plug your instrument into this 1/4" phone jack using any standard shielded guitar cord.

BASS, MID and TREBLE CONTROLS. These controls allow the frequency response of the amplifier to be tailored as desired.

GAIN CONTROL. This control is located prior to the CMOS overdrive Circuitry. The more this control is turned up the more the overdrive circuitry saturates (musically distorts); this distortion harmonically enriches the signal and increases the sustain of the note. The GAIN control is used in combination with the MASTER level control to achieve the desired tone quality at the desired volume (see the Section on OPERATION).

REVERB CONTROL (not shown, STINGER 60 only). This control determines the proportion of delayed signal mixed with the normal, "dry" signal.

MASTER LEVEL CONTROL. The overall volume of the amplifier is determined by the MASTER level control. It is used in conjunction with the GAIN control to determine the degree of sustain and distortion and volume of the amp.

SPEAKER MUTE SWITCH. Pressing the SPEAKER MUTE switch so that it remains in its "in" position disconnects the STINGER's internal loudspeaker; the amplifier's output signal is still available at the HEADPHONES/LINE OUT jack. This permits practicing through headphones without disturbing others in the same room. Pressing the switch a second time returns the switch to its "out" position, and restores operation of the speaker.

HEADPHONES/LINE OUT JACK. This 1/4" phone jack has three primary uses:

1. To deliver a monophonic signal to mono or stereo headphones.
2. To deliver a line level signal to an auxiliary power amplifier when more power is needed, or
3. To provide a direct send to the mixing console of a PA system or recording setup.

The amplifier output signal is wired through isolation resistors to both the "ring" and "tip" connections of the stereo style HEADPHONES/LINE OUT jack. This allows either a mono or stereo 1/4" phone plug to be used on the headphones or patch cord.

Always use shielded cable when patching from the HEADPHONES/LINE OUT jack to the input of another piece of equipment.

AC POWER SWITCH. The lighted rocker switch turns the STINGER'S AC power on and off.

WARNING: The STINGER 20 employs a power cord with a polarized plug which can only be inserted into an outlet in one way. The power cord on the STINGER 60 has a third prong (the round one) which provides its chassis with an AC ground reference. In both cases, these are safety measures and ANY ATTEMPT TO DEFEAT THEM SHOULD BE AVOIDED.

4. OPERATION

Surveys have demonstrated that for one amplifier to sound twice as loud as another, it must put out nearly ten times the power. For this reason, it would take a 200 watt amplifier to double the apparent volume of the STINGER 20, and a 600 watt amp to double the apparent volume of the STINGER 50. This is why these amps sound so much louder than you would expect. By exploring the various controls on your STINGER, you will find that it is capable of producing not only a very satisfying output volume, but also a wide range of musical sounds.

To play clean, turn the GAIN control all the way down, the MASTER level control all the way up, and slowly turn the GAIN control up until the desired volume is achieved.

For a "screaming rock and roll" sound, turn the MASTER control completely down, the GAIN control all the way up, and bring the MASTER control up until the desired volume is obtained.

Between the extremes of clean and nasty, any amount of "grit," "crunch" and sustain may be obtained from the STINGER; just remember that advancing the GAIN control increases the distortion and sustain, and turning the MASTER control up increases the volume.

SERVICE INFORMATION: The STINGER 20 and STINGER 60 have been designed to give you years of trouble-free service. However, in the event that your amplifier should fail in any way, refer the problem to a qualified service technician, as it contains no user-serviceable parts. Contact your dealer for the location of the nearest **sunn** Authorized Service Center.

SUNN ELECTRONICS LIMITED WARRANTY

sunn Electronics warrants new electronic products to be free from defective materials and faulty workmanship for a period of three years from the date of purchase to the original owner when purchased from an Authorized **sunn** Dealer.

Speakers carry a one year warranty from date of purchase.

Light bulbs, vacuum tubes and meters carry a 90 day warranty from date of purchase.

The following conditions apply to all **sunn** product warranties:

The purchaser is responsible for completing and mailing to **sunn**, within 15 days of purchase, the warranty application enclosed with each product. Upon receipt of the warranty application, **sunn** will issue a warranty validation sticker that must be affixed to the product. Where a warranty validation area has not been provided on a few **sunn** products, the validation sticker is to be affixed to your original proof of purchase and presented at the time of warranty service. **PROOF OF PURCHASE ON UNREGISTERED EQUIPMENT IS NOT SUFFICIENT FOR RECEIVING IN-WARRANTY SERVICE.** In the event you do not receive your validation sticker within 60 days of mailing, you are to notify **sunn** ELECTRONICS in writing immediately. The purchaser has the sole responsibility of completing and mailing the warranty application.

sunn products that have been subject to accident, alteration, abuse, rental or defacing of the serial number are not covered by this warranty. Loudspeakers and drivers misuse due to overpowering or improper installation resulting in torn, burned or charred components will not be covered by this warranty.

The normal wear and tear of appearance items such as handles, corners, casters and knobs are not covered under this warranty.

If your **sunn** product requires service during the warranty period, **sunn** will repair or replace, at its option, defective materials provided you have identified yourself as the owner of the validated product to any **sunn** authorized service center or contact **sunn** for service assistance. **Transportation charges to and from an authorized service center or factory for **SUNN** products and components to effect repairs shall be the responsibility of the owner. In the event a product is to be returned to **SUNN** for repairs, a written return authorization from **SUNN** must be obtained prior to shipping.**

sunn is not liable for any incidental or consequential damages resulting from any defect or failure of this instrument other than the repair of the **sunn** product subject to the terms of this warranty. This warranty gives you specific legal rights, and you may also have other rights which vary from state to state. This warranty is expressly in lieu of all other agreements and warranties, expressed or implied, except as may be otherwise required by law.