



SX SERIES

Operators Manual

TABLE OF CONTENTS

- 1. OVERVIEW**
 - 1-1. INTRODUCTION
 - 1-2. BLOCK DIAGRAM
 - 1-3. SPECIFICATIONS
- 2. FRONT PANEL CONTROLS, JACKS AND LEDs**
 - 2-1. INPUT JACKS
 - 2-1-1. 1/4" JACKS
 - 2-1-2. XLR JACKS
 - 2-2. CHANNEL CONTROLS
 - 2-2-1. CHANNEL LEVEL CONTROL
 - 2-2-2. CHANNEL TONE CONTROLS
 - 2-2-3. EFF/REV CONTROL
 - 2-2-4. MONITOR CONTROL
 - 2-3. MASTER SECTION CONTROLS
 - 2-3-1. MAIN LEVEL CONTROL
 - 2-3-2. MONITOR LEVEL CONTROL
 - 2-3-3. REVERB CONTROL (SX4150 only)
 - 2-3-4. MAIN REVERB CONTROL (SX6350 and SX8350)
 - 2-3-5. MONITOR REVERB CONTROL (SX6350 and SX8350)
 - 2-3-6. EFF SEND CONTROL
 - 2-3-7. AUX LEVEL CONTROL (SX6350 and SX8350)
 - 2-3-8. GRAPHIC EQUALIZER
 - 2-4. PATCH BAY
 - 2-4-1. MAIN OUT
 - 2-4-2. MONITOR OUT
 - 2-4-3. EFFECTS OUT
 - 2-4-4. GRAPHIC OUT (SX6350 and SX8350)
 - 2-4-5. GRAPHIC IN
 - 2-4-6. AUX IN
 - 2-4-7. TAPE IN
 - 2-4-8. POWER AMP IN (SX6350 and SX8350)
 - 2-5. LEDs
 - 2-5-1. POWER LED
 - 2-5-2. LIMIT LED (SX6350 and SX8350)
- 3. BACK PANEL**
 - 3-1. SPEAKER OUTPUT JACKS
 - 3-2. POWER SWITCH
 - 3-3. FUSE
 - 3-4. HEATSINK
- 4. SETUP AND OPERATION**
 - 4-1. INITIAL CONTROL SETTINGS
 - 4-1-1. LEVEL CONTROLS
 - 4-1-2. MONITOR CONTROLS
 - 4-1-3. CHANNEL EQUALIZATION
 - 4-1-4. GRAPHIC EQUALIZERS
 - 4-1-5. MAIN AND MONITOR LEVEL CONTROLS
 - 4-2. USING THE GRAPHIC EQUALIZER TO ELIMINATE ACOUSTIC FEEDBACK
 - 4-2-1. THE CAUSE OF ACOUSTIC FEEDBACK
 - 4-2-2. TYPICAL PROCEDURE FOR ROOM EQUALIZATION
 - 4-3. CORDS AND CABLES
 - 4-3-1. MICROPHONE CORDS
 - 4-3-2. SPEAKER CABLES
 - 4-4. INPUT PADS
 - 4-5. PATCHING
- 5. UPKEEP AND SERVICE**

1. OVERVIEW.

1-1. INTRODUCTION.

The **sunn** SX Series integrated mixer/amplifiers have been designed for easy setup and simple but versatile operation. Requiring only the addition of microphones and speakers, the SX powered mixer is a self-contained sound reinforcement or keyboard amplification system with features and performance generally found only in units costing much more.

Each preamp channel is provided with XLR and 1/4" phone inputs, Level, Low and High frequency controls, Monitor and Effects/Reverb controls. The master sections all feature Main, Monitor and Reverb level controls, a graphic Equalizer, a power amplifier and a versatile patch bay.

The power amplifier in SX4150 is capable of driving a four ohm load to 135 watts, and the SX6350 and SX8350 contain amplifiers which drive a four ohm load to a very potent 350 watts. In addition, the SX6350 and SX8350 feature a high performance power amp limiter that senses amplifier error due to clipping, short circuit or improper load conditions, and automatically reduces the gain until the distortion is minimized. A front panel LIMIT LED indicates the actions of the limiter.

To make setup as simple as possible, the mixer, graphic equalizer and power amplifier are pre-patched in a standard configuration that requires only the microphones and speakers to be plugged in in order to be "on the air." To make the system as versatile as possible, this "normalized" patch may be bypassed by using the inputs and outputs of the patch bay. These allow the individual components of the system to be used in various combinations, and for external equipment to be added into the system as the need arises.

The SX Series has been designed to meet the needs of the professional musician, and can be counted on to provide reliable service in the most demanding situations.

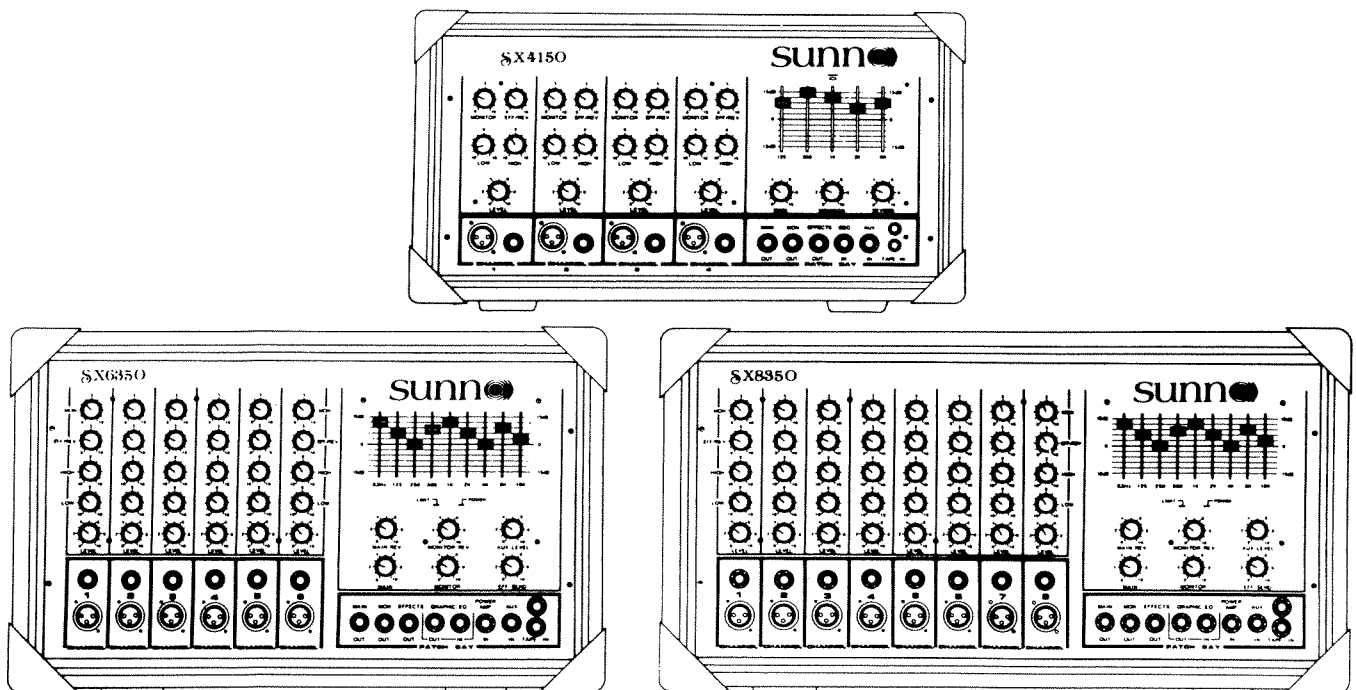

**1-2. BLOCK DIAGRAM
SX4150/SX4150B**

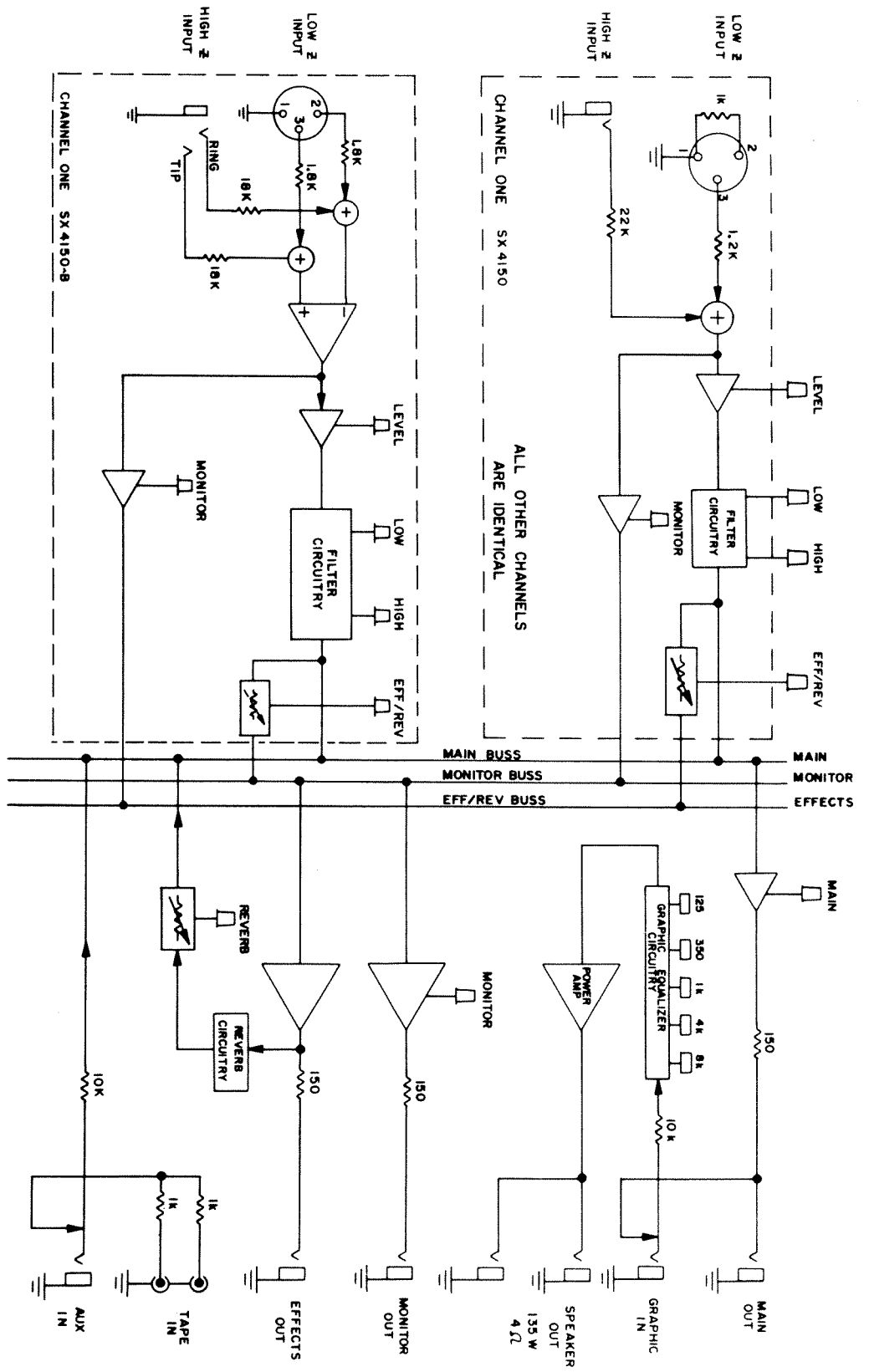

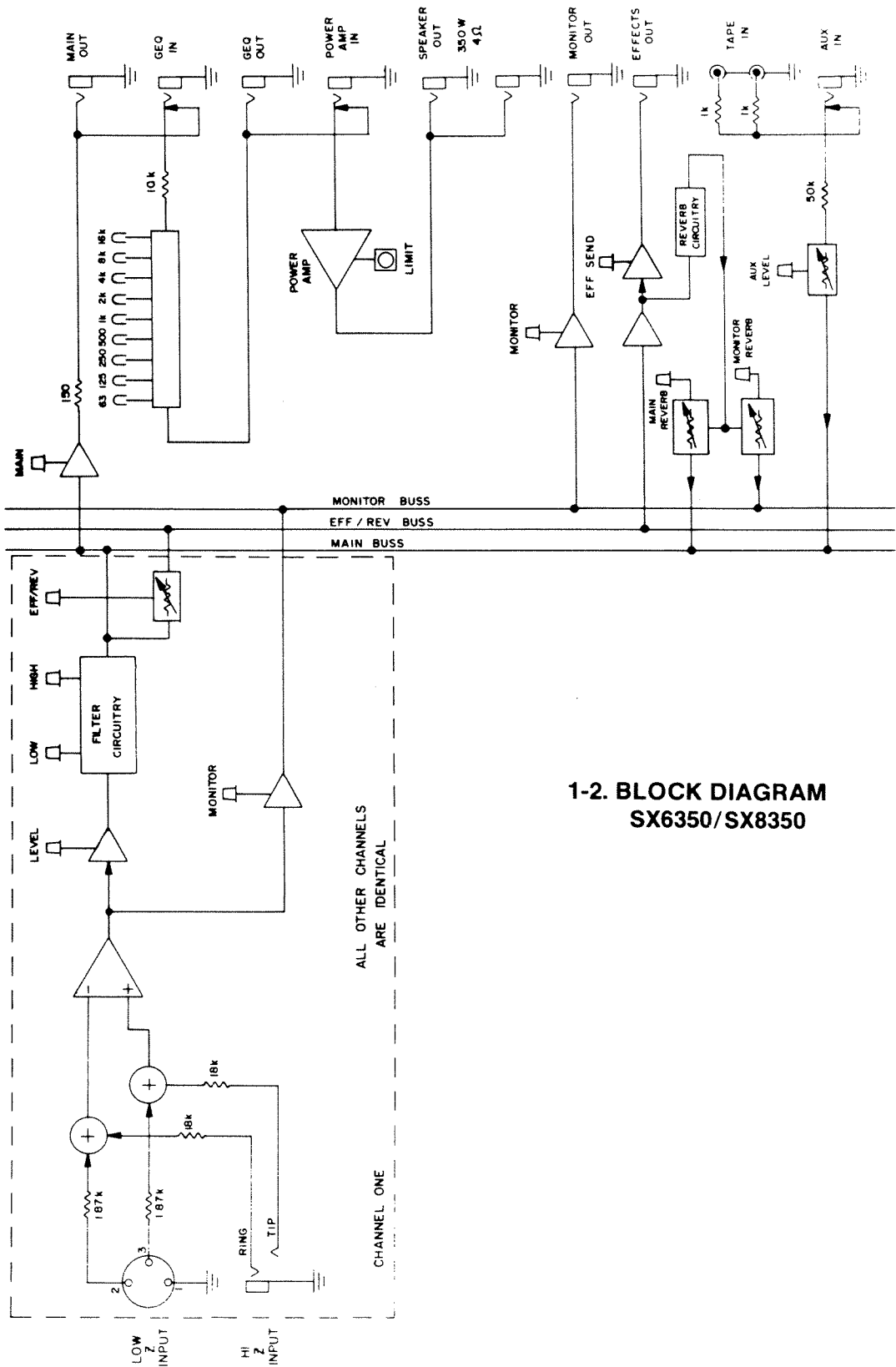

1-2. BLOCK DIAGRAM
SX6350/SX8350

1-3. SPECIFICATIONS.

All specifications refer to SX4150, SX4150B, SX6350 and SX8350 unless noted.

NOISE: Under actual operating conditions, A-weighted and referenced to 0 dBV = 1 VRMS, source impedance = 150 ohms. All channel level controls set at 5, tone controls at 0, graphic controls centered, master volume at 5.

	SX4150	SX6350	SX8350	SX4150B
MAIN OUT:	-66 dBV	-64 dBV	-64 dBV	-66 dBV
GRAPHIC OUT:	-64 dBV	-64 dBV	-62 dBV	-64 dBV
SIGNAL TO NOISE RATIO:	A-weighted, measured at rated power amp output level.			
SX4150:				+105 dB
SX4150B:				+107 dB
SX6350, SX8350:				+107 dB
DISTORTION:	All distortion measurements taken at rated output level.			
THD:	less than .05%, 50 Hz to 20 kHz			
IMD: (SMPTE)	less than .05%			
MAXIMUM THD AT FULL LIMITING (SX63/83):	less than 1%			
LIMITER DYNAMIC RANGE (SX6350, SX8350):	36 dB			
FREQUENCY RESPONSE: (Power Amplifier)	+0/-0.25 db, 20 Hz to 20 kHz			
SLEW RATE:	Power amplifier driven to rated output level			
SX4150B, SX4150:	12 volts per microsecond			
SX6350, SX8350:	25 volts per microsecond			
MAXIMUM INPUT LEVELS:	Taken at 1 kHz, tone controls at 0, output load = 4 Ω .			
	SX4150			SX4150B SX6350, SX8350
Low Z input, level control at 1:	.3 VRMS			0.5 VRMS
Low Z input, level control at 10:	10 mVRMS			16 mVRMS
Hi Z input, level control at 1:	3.1 VRMS			8.5 VRMS
Hi Z input, level control at 10:	22 mVRMS			0.26 VRMS
Aux input, level control at 10:			8 VRMS	
Graphic EQ in, controls at 0 db:	1 VRMS			8 VRMS
Power Amp in:				1 VRMS
MAXIMUM OUTPUT LEVELS:				
Main, Monitor, Effects, Equalizer output into 2 K ohms:			6.5 VRMS	
Speaker output into 4 ohms:				
SX4150 and SX4150B:	135 W RMS at less than 1% THD 50 Hz to 20 kHz 125 W RMS at less than 0.1% THD 50 Hz to 20 kHz			
SX6350 and SX8350:	350 W RMS at less than .05% THD 50 Hz to 20 kHz 300 W RMS at less than .05% THD 20 Hz to 20 kHz			

INPUT IMPEDANCES:	SX4150	SX4150B	SX6350, SX8350
Channel Low Z input:	3.2K ohms	3.6K ohms	3.6K ohms
Channel Hi Z input:	4.7K ohms	33K ohms	33K ohms
Main In:	27K ohms	27K ohms	4.7K ohms
Equalizer In:		10K ohms	
Effects In, Monitor In:		4.7K ohms	
Power Amp In:			10K ohms

OUTPUT IMPEDANCES:	SX4150, SX4150B	6350, SX8350
Main:		150 ohms
Monitor, Equalizer:		150 ohms
Effects Out:	4.7K ohms	150 ohms

2. FRONT PANEL CONTROLS, JACKS AND LEDs.

2-1. INPUT JACKS.

2-1-1. **1/4" JACKS.** The 1/4" phone jacks are intended for high impedance balanced or unbalanced inputs whose amplitude is under 8 VRMS. When used as a balanced input, the tip connection of the 1/4" jack is the non-inverting (+) input and the ring connection is the inverting (-) input. (SX6350 and SX8350):

2-1-2. **XLR JACKS.** The three-pin audio connectors (often called "XLR" or "Cannon" connectors) on the front panel are intended for balanced input signals from low impedance microphones. To avoid clipping in the input stage, signal levels should not exceed 0.8 VRMS. Higher amplitude signals, such as balanced line level signals, may also be patched into these jacks if an input pad is used (see Section 4-4).

The XLR jack is wired according to the following standard:

- Pin 1 is ground
- Pin 2 is the inverting (-) input
- Pin 3 is the non-inverting (+) input.

Signals at the XLR jacks experience 20 dB more gain than those at the 1/4" channel input jacks.

2-2. CHANNEL CONTROLS.

2-2-1. **CHANNEL LEVEL CONTROL.** The channel LEVEL control determines how much of the channel's signal is sent to the Main mixing buss and to the EFF/REV control. For best signal to noise ratio, this control should be set relatively high; usual settings are between 6 and 8, except when input signal levels are great enough to cause clipping. See Section 4-1-1.

2-2-2. **CHANNEL TONE CONTROLS.** The LOW and HIGH controls on each channel may be adjusted to enhance the qualities of its particular audio signal and to control excessive boominess or sibilance ("s" sounds) by using the LOW and HIGH controls.

When these controls are at 0, or straight up, the channel is “flat” (no frequencies cut or boosted). The most natural sound is achieved by avoiding extreme tone control settings.

2-2-3. EFF/REV CONTROL. This control determines how much signal from each channel goes onto the Effects/Reverb buss. All signals on this buss are combined in the master mixer section, and sent both to the EFFECTS OUT jack and to the internal reverb system. The EFF/REV control is wired post-LEVEL control and post-EQ; thus, the level and tone of the EFF/REV signal are altered by the settings of the LEVEL, LOW and HIGH controls.

2-2-4. MONITOR CONTROL. The MONITOR control determines how much of a channel’s signal is sent to the Monitor buss. This allows a separate mix to be created for stage monitoring. The control is wired pre-LEVEL control and pre-EQ; thus, the monitor signal is independent of other channel controls.

2-3. MASTER SECTION CONTROLS.

2-3-1. MAIN LEVEL CONTROL. This is the master level control for the main mix. It controls the signal level present at the MAIN OUT jack, and if nothing is patched into the GRAPHIC IN jack or the POWER AMP IN jack (SX6350 and SX8350), the MAIN LEVEL control also determines the graphic equalizer and power amplifier input levels.

2-3-2. MONITOR LEVEL CONTROL. This is the master level control for the monitor mix. It controls the signal level present at the MONITOR OUT jack.

2-3-3. REVERB CONTROL (SX4150 and SX4150B). This control determines how much of the signal from the reverb system is added to the main mix.

2-3-4. MAIN REVERB CONTROL (SX6350 and SX8350). This control determines how much of the signal from the reverb system is added to the main mix.

2-3-5. MONITOR REVERB CONTROL (SX6350 and SX8350). The MONITOR REVERB control determines how much of the signal from the reverb system is added to the monitor mix. Many vocalists like to hear some reverb on their voices in the monitor system; be aware that reverb in the monitors increases the likelihood of feedback in the monitor system.

2-3-6. EFF SEND CONTROL. The mix created by the settings of the channel EFF/REV controls appears at the EFFECTS OUT jack, as well as being sent to the reverb system. On the SX6350 and SX8350, the signal level at the jack is adjusted with the EFF SEND control.

2-3-7. AUX LEVEL CONTROL (SX6350 and SX8350). Signals patched into the AUX IN jack are sent to the Main buss via the AUX LEVEL control. This control determines how much of the AUX input signal appears in the main mix.

2-3-8. GRAPHIC EQUALIZER. The SX4150 and SX4150B contain a five-band graphic equalizer, and the SX6350 and SX8350 each have a nine band graphic equalizer. The equalizers consist of active filters spaced at octave intervals (one and one half octave intervals on the SX4150 and SX4150B). The lowest frequency filter is a low pass shelving filter with a high end roll-off at 63 Hz (125 Hz on the SX4150 and SX4150B) and the highest frequency filter is a high pass shelving filter with a low end roll-off at 16 kHz (8 kHz on the SX4150 and SX4150B); all others are bandpass filters centered on the frequencies indicated below their sliders. Moving the sliders up or down boosts or cuts the gain at the indicated frequencies. This allows the sound engineer to suppress

engineer to suppress feedback by compensating for room resonances in live sound reinforcement applications. The EQ controls are accurately scaled in dB to indicate the amount of cut or boost applied at each frequency.

NOTE: It is possible for distortion to occur in the Graphic Equalizer if input levels are too high, or if excessive boost is applied to a moderately high level signal.

2-4. PATCH BAY.

2-4-1. MAIN OUT. Signals from each of the channels are combined with the Effects In signal and the Main Reverb signal to form the final main mix. The overall level of the mix is controlled by the MAIN level control and this mix appears at the MAIN OUT jack. The mix is also normally passed on to the Graphic EQ and to the power amplifier (see Sections 2-4-5 and 2-4-8). Inserting a plug into the MAIN OUT jack does not interrupt the normal signal flow. The jack is useful for recording a live performance, and for inserting signal processing equipment into the signal path (see Section 4-5).

2-4-2. MONITOR OUT. Signals present on the Monitor buss are combined in the monitor amplifier and sent to the MONITOR OUT jack. The signal level present at this output is determined by the MONITOR LEVEL control.

2-4-3. EFFECTS OUT. Signals present on the Effects/Reverb buss are mixed in the effects/reverb summing amplifier, and this mix is sent both to the reverb driver and to the effects output amplifier. Thus the mix created by the settings of the EFF/REV level controls on each of the preamp channels is present at the EFFECTS OUT jack. The overall level at this output is determined by the master mixer section EFF LEVEL control. This output may be used to drive external effects (echo units, phase shifters, flangers, digital delays, etc.). The return signal from the effect may be patched into the mixer through the AUX IN jack, or by way of a preamp channel 1/4" input jack. Use of a preamp channel as a return gives you the ability to shape the frequency response of the signal; however, care must be taken to insure that the EFF/REV control on that channel is turned all the way down — otherwise a feedback loop will exist which could cause oscillation and possible damage to speakers. Care must be taken to insure that the amplitude of the return signal is not too great for the preamp channel input; an input pad may be used if needed.

2-4-4. GRAPHIC OUT (SX6350 and SX8350). The output of Graphic Equalizer is present at the GRAPHIC OUT jack; inserting a plug into this jack does not interrupt the normal signal path. The jack is useful for patching more power amplifiers into the system, for post-equalizer recording, and for inserting signal processing equipment (limiters, parametric equalizers and the like) between the equalizer and the power amplifier (see Section 4-5).

2-4-5. GRAPHIC IN. The graphic equalizer is prepatched to the main output signal. However, the GRAPHIC IN jack allows this "normalized" patch to be defeated; inserting a 1/4" phone plug into the jack disconnects the equalizer from the main signal and instead connects it to any signal carried by the phone plug. This allows the equalizer to be patched to other SX outputs or to other pieces of audio equipment.

2-4-6. AUX IN. This input is generally used as a return from an external signal processing device (flanger, phase shifter, etc.). Signals present at this input are routed to the Main buss by way of the AUX LEVEL control in the SX6350 and SX8350 and directly to the Main buss in the SX4150 and SX4150B. In emergencies, it is possible to use the AUX IN as a line level preamp channel, although it lacks the preamp channels' equalization, monitor and effects sends (and level control on the SX4150 and SX4150B).

2-4-7. TAPE IN. Patching the output of a tape deck into the two phono (RCA) jacks produces a monophonic image of the signal in the main mix. This is useful for playing music during breaks in the performance. In the SX4150 and SX4150B, this signal passes directly to the Main buss, and in the SX6350 and SX8350 the signal level is controlled by the AUX LEVEL control. The TAPE IN jacks are disconnected whenever a plug is inserted into the AUX IN jack.

2-4-8. POWER AMP IN (SX6350 and SX8350). Under normal circumstances, the power amplifier receives its input from the Graphic Equalizer. However, by inserting a 1/4" phone plug into the POWER AMP IN jack, the normal signal path is broken and any signal carried by the phone plug becomes the power amplifier's input. This allows the power amplifier to be used independently from the rest of the SX powered mixer. Possible uses of this feature include dedicating the power amp to the monitor system while employing an auxiliary power amplifier for the mains, or using the SX power amp as one of two power amplifiers in a biamped system (this would require the addition of an external crossover). See Section 4-5.

2-5. LEDs.

2-5-1. POWER LED. The green LED (Light Emitting Diode) is the front panel "power on" indicator.

2-5-2. LIMIT LED (SX6350 and SX8350). The red LIMIT LED comes on when excessive signal levels are being sent to the power amp or if an improper load, such as a shorted speaker cord or loudspeaker, is connected to the amplifier output. The LIMIT LED is driven by circuitry which senses distortion in the power amplifier. This circuitry also activates the power amp limiter which responds to the sensed distortion by decreasing the gain of the power amplifier just enough to prevent clipping (a harsh type of distortion which can damage loudspeakers). If the limiter is on for a large percentage of the time the dynamic range of the system is reduced and the overall sound suffers; for this reason, level controls should be adjusted so that the LIMIT light only flashes on occasional signal peaks.

3. BACK PANEL.

3-1. SPEAKER OUTPUT JACKS. These are the speaker outputs for power amplifier. The SX4150 and SX4150B power amp is capable of driving a 4 ohm load to 135 watts, and the SX6350 and SX8350 power amplifiers can drive a 4 ohm load to 350 watts. Do not connect loads with impedances lower than 4 ohms to the SPEAKER OUTPUT, as this may result in amplifier overheating. (To calculate the speaker impedance, see Section 4-3-2.) In addition, be sure that the speaker cable you use is of adequate gauge; otherwise, power will be lost in the wire instead of being delivered to the speaker, and the damping factor will be impaired (see Section 4-3-2).

3-2. POWER SWITCH. AC POWER to the SX powered mixer is turned on and off by a rocker switch located on the back panel. If you have any external signal processing devices patched to the system, turn them on first to avoid pops in the loudspeakers. Also, when you turn on the mixer, make sure that the main fader is down — this eliminates the risk of the system immediately feeding back when it is turned on, and also minimizes turn-on pops.

WARNING! Do not remove the grounding prong of the AC plug. To do so risks exposure to potentially lethal voltages and voids the warranty.

3-3. FUSE. The fuse is located immediately below the POWER switch. Before attempting to replace a blown fuse, TURN THE POWER SWITCH OFF and check all input and output cables to be certain that they are correctly connected. The fuse may be removed by inserting the tip of a small screwdriver or other sharp object (bent paper clip, etc.) into the slot in the top of the fuse holder. The cap should pop partially out, bringing the fuse with it. Replace the fuse only with one of the same type and rating. If the fuse blows repeatedly, there may be a problem with the load or with the powered mixer itself. Load problems include shorted speaker cables or loudspeakers, or a load whose impedance is too low (see Section 4-3-2). If the problem is in the mixer, refer it to authorized service personnel.

3-4. HEATSINK. HOT! (This is normal.) For reliable operation, do not restrict airflow to the heatsink.

4. SETUP AND OPERATION.

FIGURE 1 illustrates the simplest way to set up your PA system.

FIGURE 1

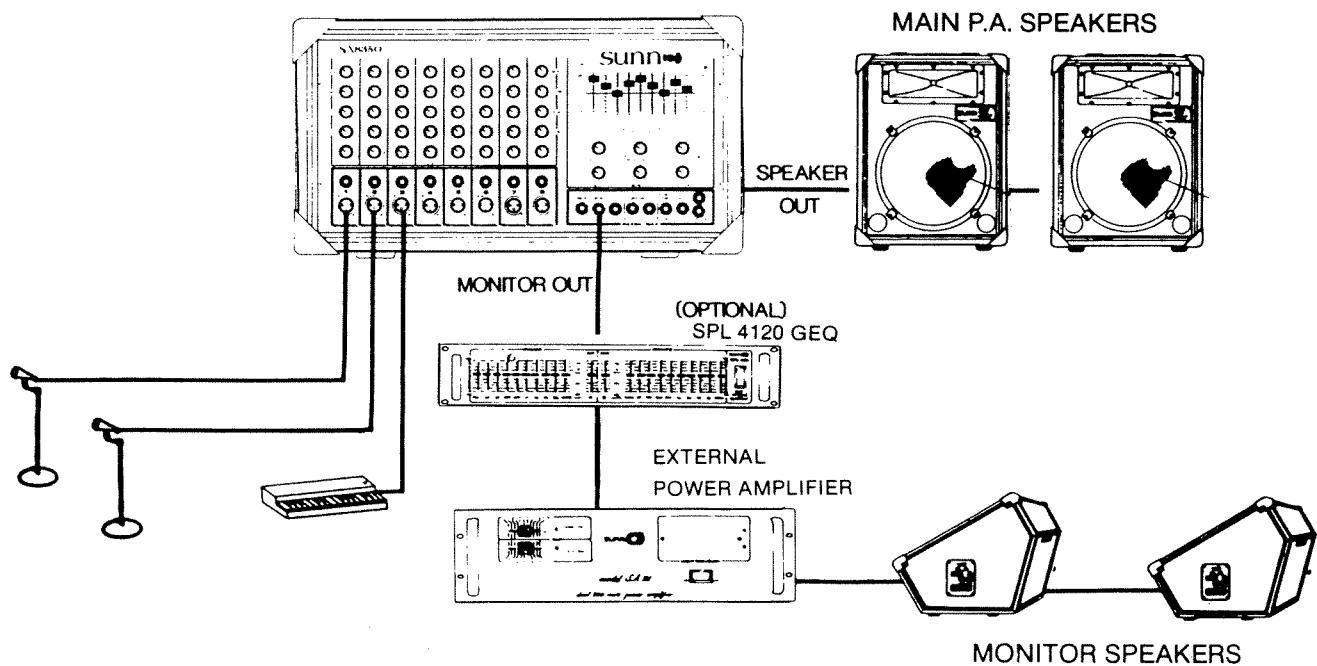

4-1. INITIAL CONTROL SETTINGS. When you first set up the sound system, initial settings are critical for arriving at a satisfactory mix quickly. Often, to the distress of many soundmen, the show must begin without a preliminary sound check. The following recommendations should help to alleviate some of the soundman's headaches.

4-1-1. LEVEL CONTROLS. Try setting the channel LEVEL controls between 6 and 8; this allows the channel output to be boosted if necessary, and provides a good signal-to-noise ratio in the system. Be ready to adjust the LEVEL controls quickly since without proper gain adjustment the rest of the mix cannot correct for the error.

When using drum mics, guitar amp mics and other high level signal sources, lower settings may be necessary to avoid distortion. If distortion cannot be eliminated by turning down the LEVEL control, an input pad may be required (see Section 4-4).

4-1-2. MONITOR CONTROLS. Most groups like to hear their voices in the monitors; some also like to hear certain instruments as well (bass drum, bass guitar, and so forth). A good initial MONITOR control setting is 5, or straight up. Assuming that the various vocalists use similar miking techniques and sing at similar volumes, the levels appearing in the monitor mix should be fairly well matched. Further adjustments can be made as needed.

4-1-3. CHANNEL EQUALIZATION. For starters, most vocal, keyboard and other full-range signals are best left flat (controls at 0, or straight up). For signals having a great deal of low frequency content, such as drums and bass guitars, the LOW control should initially be backed off slightly (rotated to the left) from the 0 position to reduce boominess. Naturally, all controls should be set to achieve the most pleasing sounds, but the settings listed above should help in achieving good results quickly. In general, extreme settings cause the sound to be unnatural and should be avoided.

4-1-4. GRAPHIC EQUALIZERS. Start out with the equalizers set "flat" (0 db). On the SX6350 and SX8350, the 64 Hz control may be set initially 3 to 6 dB below the center position, since excessive low frequencies rob power from the rest of the system and low-end feedback can damage loudspeakers. Section 4-2 gives hints on making further adjustments to the equalizers.

4-1-5. MAIN AND MONITOR LEVEL CONTROLS. The MAIN and MONITOR controls should initially be all of the way down. The MAIN control should then be adjusted to bring the volume of the system up to the desired level. The LIMIT LED on the SX6350 and SX8350 should flash only on occasional signal peaks. The MONITOR control should be moved up CAUTIOUSLY until the stage monitor volume is at a satisfactory level — be very sensitive to possible acoustic feedback.

4-2. USING THE GRAPHIC EQUALIZER TO ELIMINATE ACOUSTIC FEEDBACK.

4-2-1. THE CAUSE OF ACOUSTIC FEEDBACK. Acoustic feedback in a sound system is the result of coupling between the speakers and microphones. The microphones will always pick up a certain amount of signal from the speakers; how much they pick up depends on the room acoustics, the frequency response of the microphones and speakers and the mic and speaker placement. If the received signal is amplified enough (in the mixer and power amplifier) the speakers will continue to produce the signal, and the characteristic howl of acoustic feedback will begin. This feedback will occur at the frequency which receives the largest amount of gain from the sound system (including the room). If the signal can be attenuated at that frequency, more gain can be added to the rest of the signal frequencies before feedback occurs. This is the primary role of an equalizer in a sound system.

4-2-2. TYPICAL PROCEDURE FOR ROOM EQUALIZATION.

1. Set up your entire sound system the way it will be used, including all auxiliary equipment, and adjust it the way you would normally use it. If feedback occurs during setup, reduce the gain of the mixer with the MAIN and MONITOR level controls. Follow the procedure outlined in the paragraphs below, first for the main system and then for the monitors (assuming you are using an equalizer in your monitor system —highly recommended).
2. Set the controls on the graphic equalizers to the “flat” position, indicated as “0 dB” on the panel.
3. Slowly increase the output level (using the appropriate level control) until the sound system is on the threshold of feedback — a ringing sound will occur when you tap on the microphones.
4. Slowly attenuate the Equalizer control which has the greatest effect on reducing the ringing. This will take some trial and error — the first ringing usually occurs between 1 kHz and 4 kHz. Continue until the ringing has stopped.
5. Again, slowly increase the output level control until the system is on the verge of feeding back. Adjust the equalizer to remove the potential feedback. Continue this procedure until you have achieved sufficient gain for your application or until the equalizer becomes ineffective at removing the ringing. (It is best to back off the gain once maximum gain before feedback has been established). Avoid extreme settings or settings which require a large amount of cut in the middle frequency bands, as such settings impair intelligibility.
6. “Fine tune” the equalizer settings as the performance progresses to achieve the best overall sound from the system.

4-3. CORDS AND CABLES.

4-3-1. MICROPHONE CORDS. On the SX4150B, SX6350 and SX8350, which have balanced inputs, use balanced two-conductor shielded cable for all long runs. Balanced systems are capable of rejecting noise introduced from such sources as cash registers, electric motors and triac-controlled lights. If a balanced cable is connected to an unbalanced output (e.g., a keyboard mixer output) or microphone, use a balancing transformer close to the unbalanced device. This ensures maximum common-mode noise rejection for the entire system.

Although the SX4150 does not have balanced inputs, it is designed to be compatible with balanced signals. To take advantage of a balanced system's noise rejection on the SX4150, balanced signals may be patched into the 1/4" inputs through balancing transformers.

If you have no choice and must use unbalanced cables, use the shortest cables possible and keep them away from AC power mains, lighting cables and speaker wires. If you want the quietest system possible, you should follow these rules with balanced lines as well.

4-3-2. SPEAKER CABLES. Use two conductor zip cord to connect the amplifier outputs to your speakers. The gauge of the wire is important; wire that is too light in gauge causes a loss in damping factor (the ability of the amplifier to control the motion of the speaker) and also consumes power (the power from the amplifier heats up the wire instead of driving the speakers). Use Figure 2 to choose the proper gauge of wire for your particular situation. To calculate your speaker impedance, use Figure 3.

Speaker Wire Length

100' - Up	8	10	12	14
50 - 100'	10	12	14	16
*25 - 50'	12	14	*16	18
10 - 25'	14	16	18	18
0 - 10'	16	18	18	18
	2	4	*8	16 ohms

Speaker Impedance

*Example - The length of speaker wire required is between 25 and 50 feet and the speaker impedance is 8 ohms. The minimum recommended gauge speaker wire is 16 gauge.

FIGURE 2

CHART A
Parallel Impedance

$$RT = \frac{1}{\frac{1}{R_1} + \frac{1}{R_2} + \dots + \frac{1}{R_t}}$$

Cabinet B Impedance	16	1.8	3.2	5.3	8
	8	1.6	2.7	4	5.3
	4*	1.3	2	2.7*	3.2
	2	1	1.3	1.6	1.8
		2	4	8*	16

Cabinet A Impedance

*Example - Cabinet A is 8 ohms, Cabinet B is 4 ohms. The total impedance when connected in parallel is

$$= \frac{1}{\frac{1}{8} + \frac{1}{4}} = 2.7 \text{ ohms.}$$

FIGURE 3

CHART B
Series Impedance

$$RT = R_1 + R_2 + \dots + R_t$$

Cabinet B Impedance	16*	18	20*	24	32
	8	10	12	16	24
	4	6	8	12	20
	2	4	6	10	18
		2	4*	8	16

Cabinet A Impedance

*Example - Cabinet A is 4 ohms. Cabinet B is 16 ohms. The total impedance when connected in series is = 4 + 16 = 20 ohms.

4-4. INPUT PADS. If input signal levels are too great, the input stage may be overdriven and cause distortion. The solution in such cases is to use an input pad. A 30 dB pad can be made by using a Switchcraft connector (part #S3FM) with the resistor network shown in Figure 4.

FIGURE 4

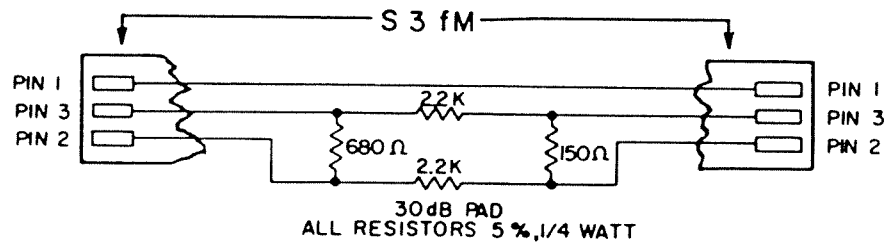

4-5. PATCHING. Figures 5 through 8 show possible ways of patching external equipment into the SX mixer. They are by no means the only patches possible. If you want to try a patch that is not illustrated, consult the Block Diagram to determine if your patch is possible. When patching external equipment into the signal chain, best results will be obtained by following these rules:

- Use the highest quality patch cords available and keep them as short as possible.
- Avoid patching a buss output back into its input (an example of this is patching a phase shifter from the EFFECTS OUT and returning it to the input of a channel which has its EFF/REV control turned up); doing so may result in oscillation (possibly inaudible) that can damage loudspeakers and create distortion.
- Do not use a mic level effect, such as an effect intended for guitar, with a line level signal, such as the Main or Graphic EQ output.

Using auxiliary power amp for more output

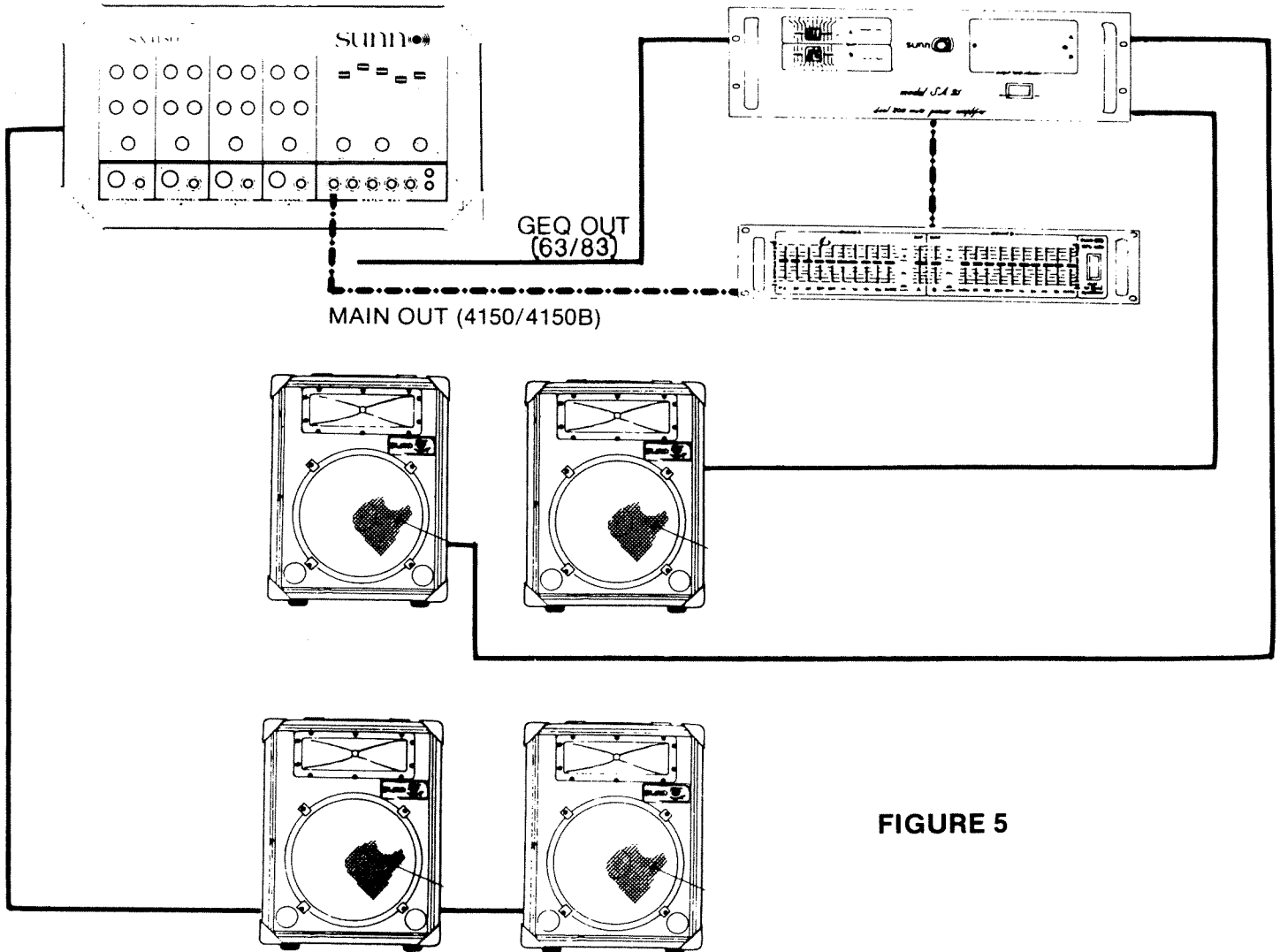
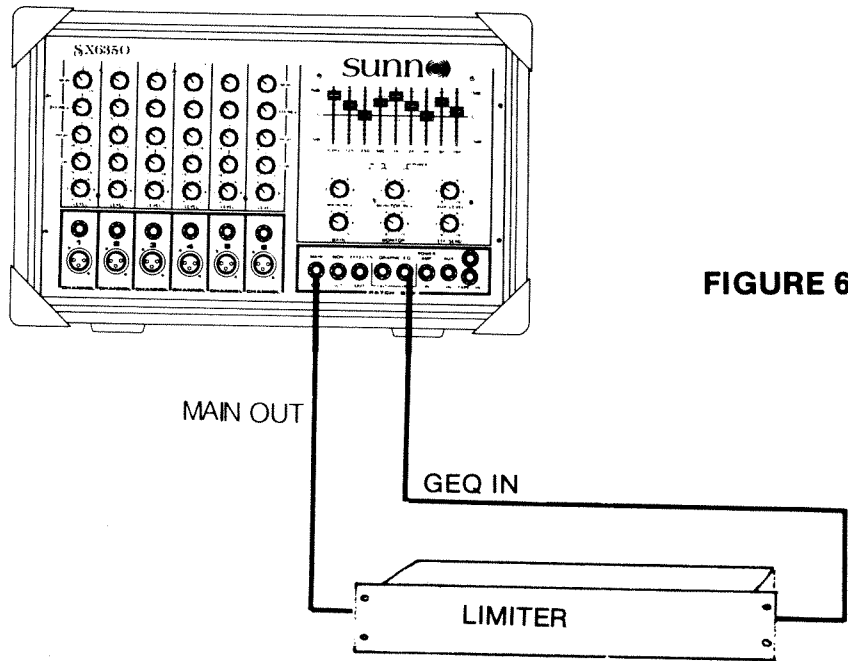

FIGURE 5

Using a limiter or other signal processing device in line with the Main signal path.



Patching an effect between the EFFECTS OUT and the AUX IN.

EFFECTS PATCHING

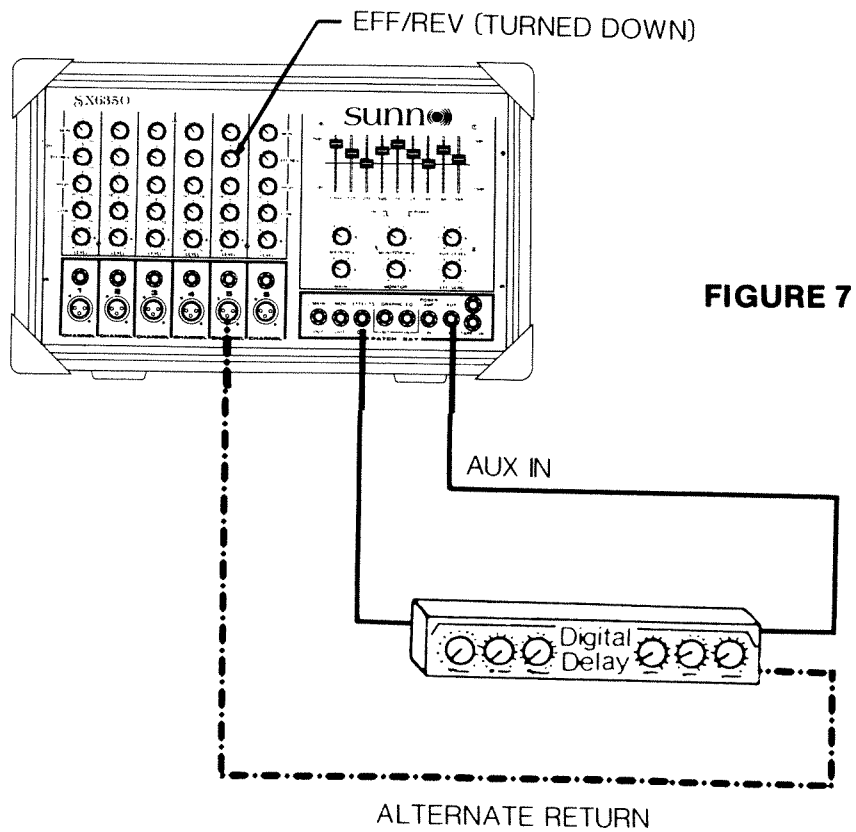

Biamping the main PA system.

BIAMPING

FIGURE 8

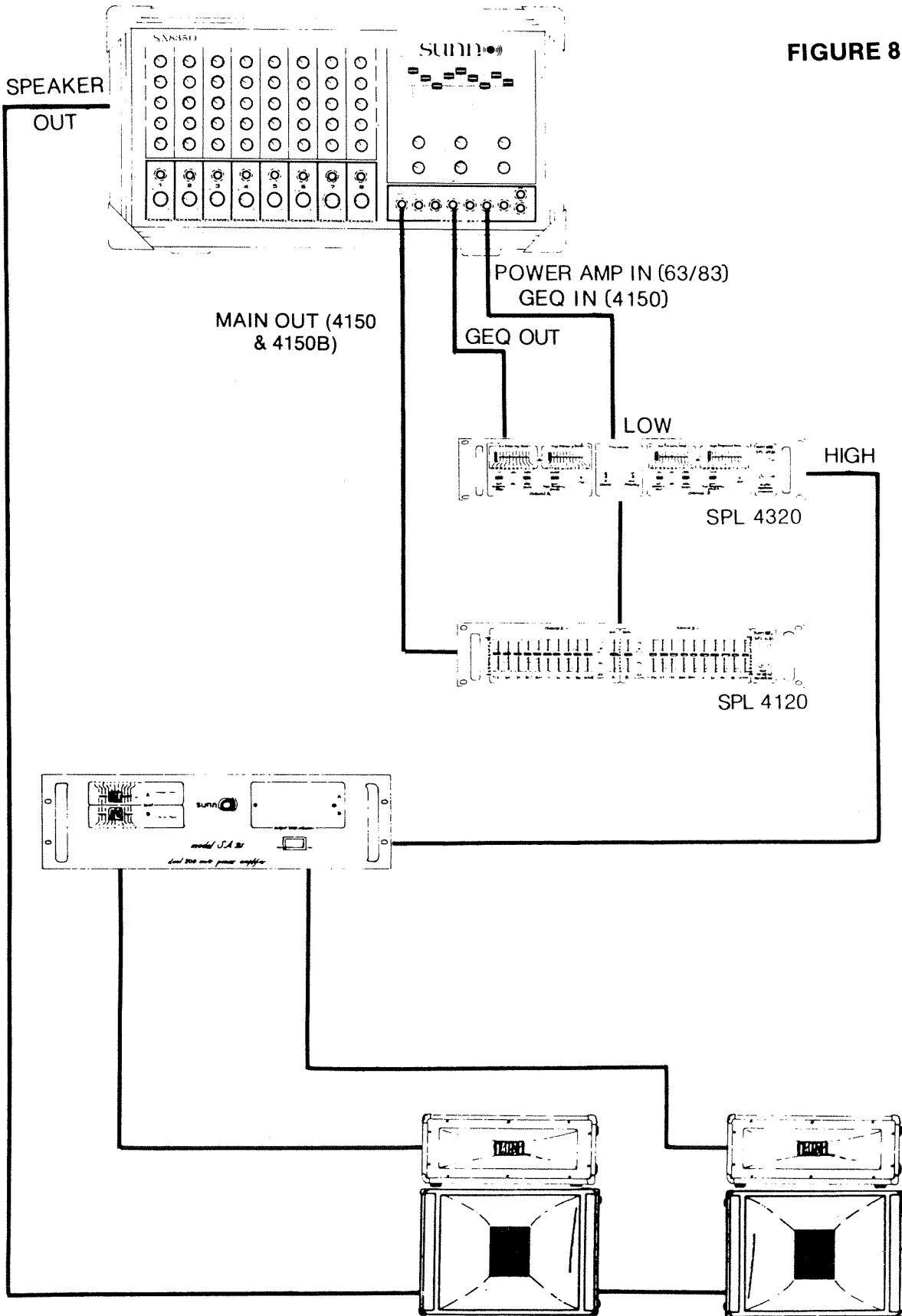

5. UPKEEP AND SERVICE.

The **sunn** SX powered mixers have been designed to give you years of trouble-free service. With a few precautions you can help to insure its continued reliable operation:

- Do not obstruct the cooling fins of the heatsinks.
- Transport the mixer with care.
- Periodically check the mixer for loose screws and tighten as necessary, being careful not to overtighten.
- If you leave the mixer set up when you are not using it, protect it from dust with a soft cover.
- DO NOT SET FOOD OR DRINKS ON THE SX POWERED MIXER - this point can not be overemphasized. Spilling a drink is the quickest way to ruin a potentiometer (fader, level control, EQ control) or switch.
- When using the mixer outdoors, protect it from moisture (rain, sprinklers, beer, etc.).
- Periodically clean the mixer by wiping it with a soft cloth and a small amount of furniture polish.

There are no user-serviceable parts in the SX series of powered mixers; therefore, any problems should be referred to qualified service personnel. Contact your dealer for the location of the nearest **sunn** Authorized Service Center.

